

# AP-1 Price Computing Scale

- 28 PRESET PRICING
- ACCUMULATION & TOTAL FEATURE
- STANDARD TOWER DISPLAY
- DELI, CAFETERIA, CANDY



**CAS**  
S · C · A · L · E

# AP-1



## FEATURES

- 200 TOTAL PLU's
- 28 PRESET KEYS
- TARE, TARE SAVE, PREPACK, ADD+TOTAL FEATURES
- AUTO SPAN CALIBRATION
- TOTAL/WEIGHT/UNIT PRICE 6/5/6 DIGITS
- 1/2 + 1/4 KEYS WHERE LEGAL
- "NTEP" APPROVED, LEGAL FOR TRADE
- OPTIONS
  - PRODUCE PLATTER : 17.3 (W)×10 (D)×2 (H) in  
440 (W)×255 (D)×50 (H) mm

## SPECIFICATIONS

WEIGHING CAPACITY	15 × 0.005 lbs (6 kg × 2 g)	30 × 0.01 lbs (15 kg × 5 g)
MEASUREMENT TYPE	LOAD CELL	
OPERATING TEMPERATURE	-10 °C ~ +40 °C	
POWER SOURCE	AC 115 V / 60Hz	
POWER CONSUMPTION	APPROX. 10W	
DIMENSIONS (W×D×H)	13.8 × 12.8 × 20 in.	
TRAY SIZE (W×D)	13.5 × 8.5 in.	
PRODUCT WEIGHT	17.2 lbs	

## DIMENSIONS

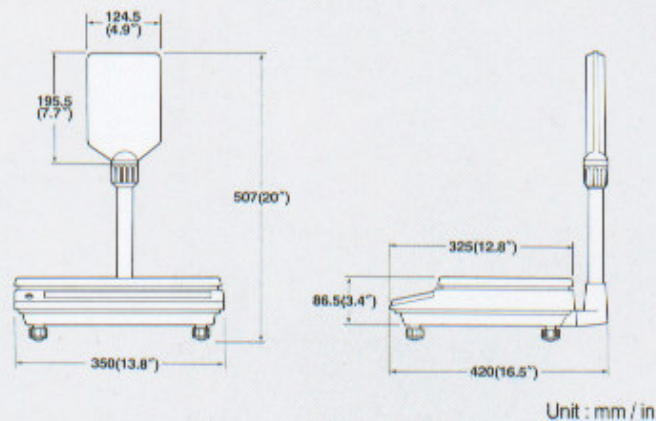

**CAS CORP.**  
Computer And Sensors

CAS(U.S.A) CORPORATION  
N.J. OFFICE  
99 MURRAY HILL PARKWAY  
EAST RUTHERFORD, NEW JERSEY 07073  
TEL : (201) 933-9002  
FAX : (201) 933-9025

CA OFFICE  
4879E. LA PALMA AVE., UNIT 207  
ANAHEIM, CA 92807  
TEL : (714) 693-1936  
FAX : (714) 693-9213



call: 561-582-5510 email: info@cashregisterservices.net

Specifications subject to change with or without notice  
Please contact us for special item & special delivery